

Project:	Quantity:
Model #:	Approval:

For Commercial Use Only

TMB25 25" Slanted Glass Bakery Display Case Refrigerator



FEATURES

- Brilliant internal LED lighting under shelf and base
- (3) Adjustable glass shelves
- Digital temperature control and display
- Double tempered glass
- (4) casters with (2) brakes
- Ventilated cooling system
- Automatic defrost

The Marchia refrigerated countertop food display case includes LED lighting and adjustable shelves as well a user accessible digital temperature controller. Insulated sliding rear doors provide employee access.

- cETLus Listed
 - ETL Sanitation listed
- Conforms to NSF/CSA Standard



USR Brands is a US supplier of premium quality commercial cooking, refrigeration and food preparation equipment. Our aim is simple. Produce industry-leading commercial restaurant equipment at reasonable prices, and back it all up with an easy to understand, no nonsense warranty that people can count on.

Project:	Quantity:
Model #:	Approval:

For Commercial Use Only

TECHNICAL DATA

DIMENSIONS

Exterior Dimensions	25.6"L x 31.7"D x 56.9"H
Packaging Dimensions	29.5"L x 35.2"D x 60.4"H
Net Volume	12.4 cu. ft.
Unit Weight	298 lb.
Shipping Weight	348 lb.

ELECTRICAL

Voltage	110-120
Hertz	60
Phase	1
Wattage	480
Amps	3.3
Lamp Power Wattage (LED)	7
Plug Type	NEMA 5-15P
Power Cord Length	72"

COOLING

Temperature Range	36.6°F to 47.4°F
Refrigerant	R290
Defrosting	Automatic
Temperature Controller	Digital

CONSTRUCTION

Exterior Material	Glass and Stainless Steel
Shelf Quantity	3
Shelf Size	Top: 23"L x 15.6"D Middle: 23.3"L x 15.6"D Bottom: 23.3"L x 18"D
Shelf Material	Glass
Adjustable Shelf	Yes
Interior Light	L.E.D
Mobility Wheels/Casters	(4) Qty: 2 with brakes, 2 without

TECHNICAL DRAWING

MODEL: **TMB25**

MFR ITEM #:



NEMA 5-15P

FRONT VIEW

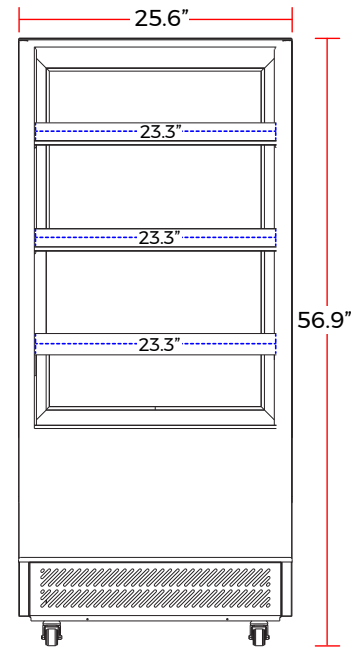

SIDE VIEW

